

Preparation unit——GA Series

GAFR100 Series filter & regulator



Symbol

Reflux valve option is not available



Specification

Model	GAFR100M5	GAFR10006
Fluid	Air	
Port size [Note1]	M5	1/8"
Filtering grade	40µm or 5µm	
Pressure range	0.15~0.9MPa(20~130psi)	
Max. pressure	1.0MPa(145psi)	
Proof pressure	1.5MPa(215psi)	
Temperature range	-5~70°C(Unfreeze)	
Capacity of drain bowl	6CC	
Weight	80g	

[Note1] PT thread, G thread and NPT thread are available.

Ordering code

GAFR100 06 S W G

① ② ③ ④ ⑤ ⑥ ⑦ ⑧ ⑨ ⑩

① Model	② Bowl material	③ Port size	④ Drain type	⑤ Type code	⑥ Accessories	⑦ Pressure gauge	⑧ Filtering grade	⑨ Thread type [Note2]	⑩ Code of reflux valve
GAFR100:GA100 Series Filter & regulator	Blank : PC	M5: M5 06: 1/8"	Blank: Semi-auto drain +Manual drain	S: Standard L: Lower pressure [Note1]	Blank: Bracket J: No bracket	Blank: Circular N: No gauge	Blank: 40µm W: 5µm	Blank: PT (MPa/psi) G: G (bar/MPa) T: NPT (psi/bar)	Blank: Reflux valve is not available

[Note1] The working pressure range of lower pressure type is 0.15~0.4MPa(20~58psi) ;

[Note 2] Thread type means connecting thread and scales of pressure gauge while port size is M5.

Pressure and Flow chart

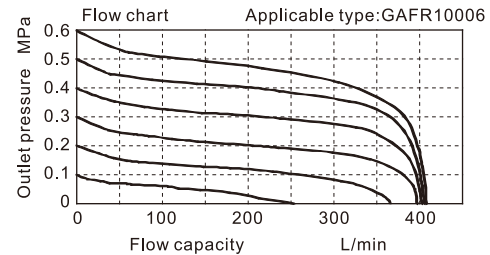
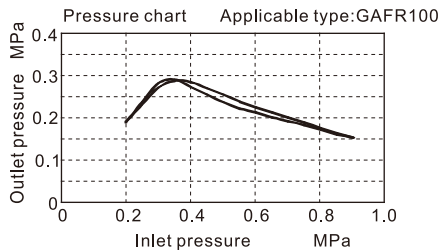

Dimensions

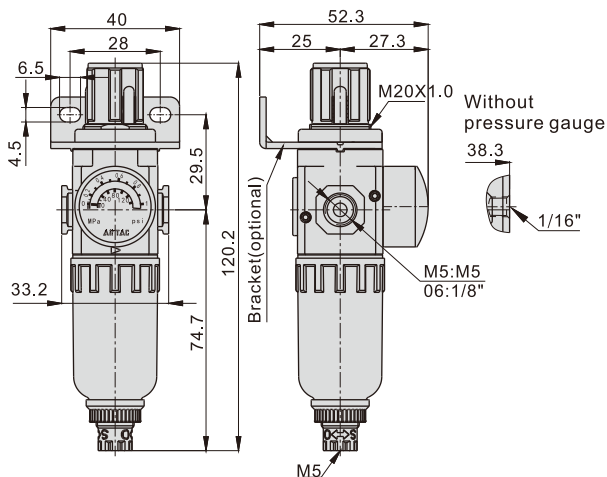

Inner structure

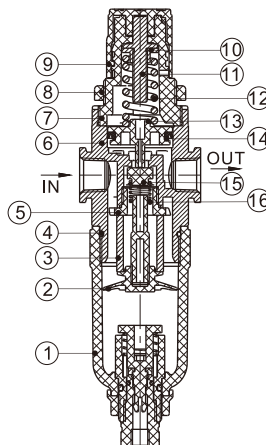

No.	Item	Material
1	Drain bowl	PC
2	Umbrella baffle	POM
3	Filter core	HDPE
4	O-ring	NBR
5	Air guider	POM
6	Body	Aluminum alloy
7	Adjusting seat	POM
8	Fixation ring cap	POM
9	Pressure knob	POM
10	Spindle nut	Steel
11	Adjusting spindle	Steel
12	Spring	Spring Steel
13	Piston	POM
14	Piston O-ring	NBR
15	Adjusting plug	NBR
16	Spring	Stainless steel